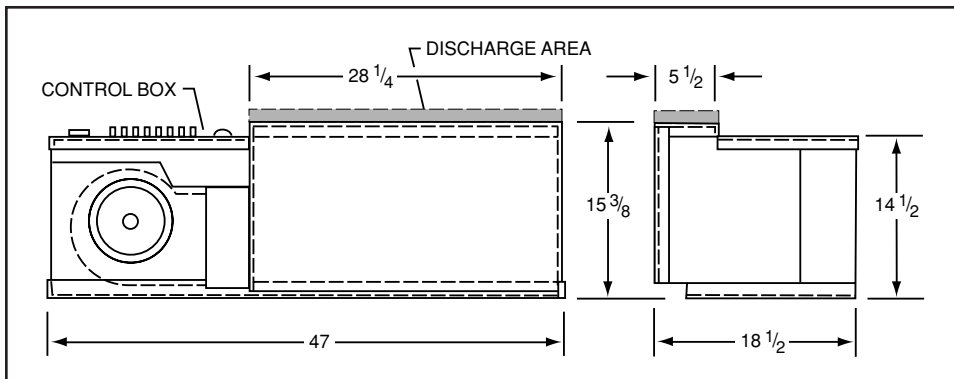
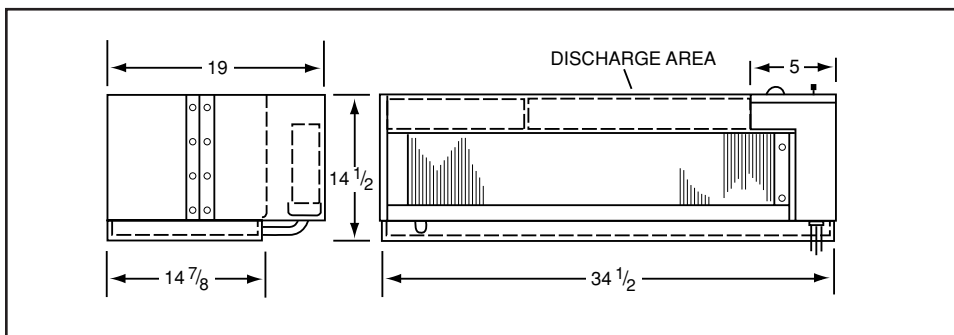

TYPE CFOO SERIES**Replacement Packaged Terminal Air Conditioners**

Replaces Original Fedders® Unizone, Climatrol®, Climazone® UVK, UVW, UUY and Airtemp® Tempzone Cooling and Heatpump Chassis.

Select NEMA cord from page 5.

TYPE CA450 SERIES**Replacement Packaged Terminal Air Conditioners**

Replaces Original American Standard®, Singer® Type SG45 and 45, Carteret® Type 45, McQuay® Type PNES2 and PNHS2 Cooling and Heatpump Chassis.

Select NEMA cord from page 5.

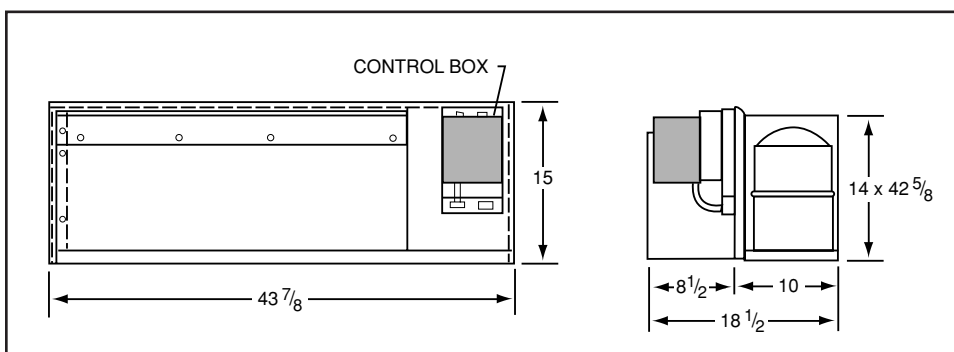
TYPE CRSO SERIES**Replacement Packaged Terminal Air Conditioners**

Replaces Original Singer® and McQuay® Type S, ES, RS, MQT PMES and PMRS Cooling and Heatpump Chassis.

Note advise factory:
Coil Placement - High or Low
Extendaire or Ducted Application.

Select NEMA cord from page 5.