

## TYPE CNIIO SERIES

### Replacement Packaged Terminal Air Conditioners

Replaces Original Dunham Bush® Newport, III, IV, and V Cooling and Heatpump Chassis.

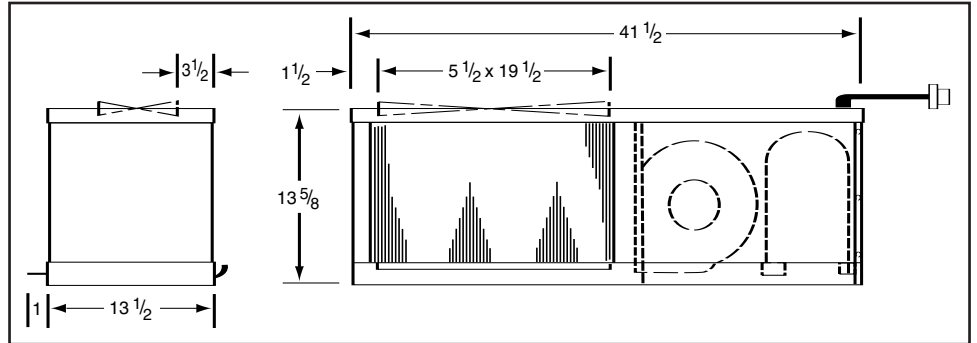

## TYPE CAF250 SERIES

### Replacement Packaged Terminal Air Conditioners

Replaces Original American Air Filter®, McQuay® Type 25, GXY and XY, Nelsonaire® Type 25 Cooling and Heatpump Chassis.

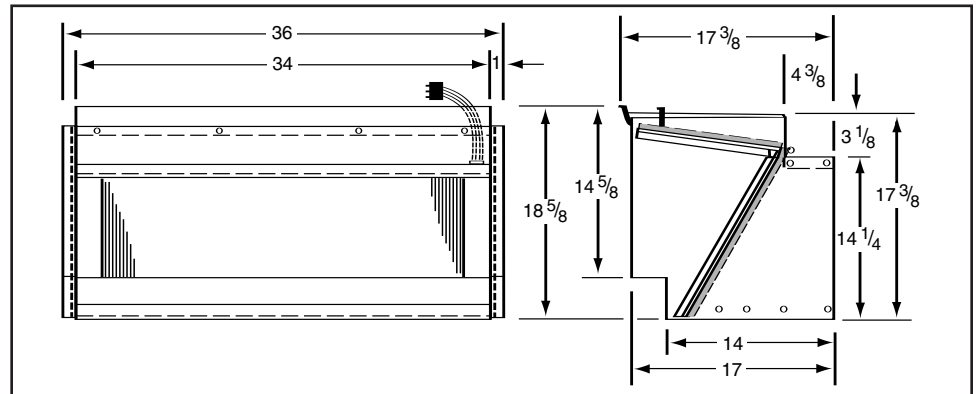

## TYPE CA410 SERIES

### Replacement Packaged Terminal Air Conditioners

Replaces Original American Standard® Series 41, McQuay® and Remotaire® Cooling and Heatpump Chassis.

