

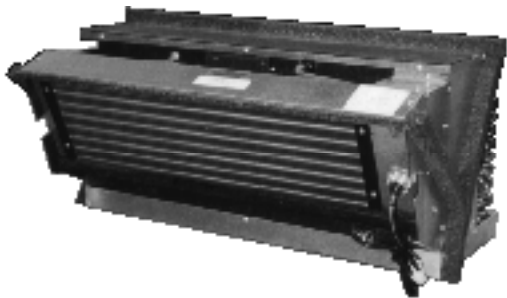

COMITALE NATIONAL INC.

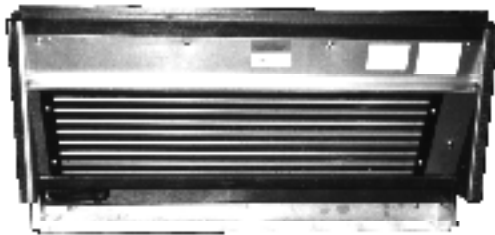

Tru-Fit™
**Chassis Operation,
Maintenance and
Repair Guide**



PTAC-PTHP
**Packaged Terminal
Air Conditioner
Thru the Wall Units**



Comitale National Inc.
1683 B Winchester Road
Bensalem, PA 19020
215-244-9650
Fax: 215-244-9679
email: cnitrufit@aol.com
www.comitalenational.com

Original Equipment Manufacturer of
Custom Packaged Terminal Air Conditioners and
National H.V.A.C. Parts Distributor

Inspection

Immediately upon receipt of equipment, inspect each carton for shipping damage. Before accepting delivery, make notations of damage on all copies of Bills of Lading and have all copies countersigned by delivering carrier.

File a claim with the carrier for any damage.

Installations/Disclaimer

When installing **Comitale National, Inc.** "Tru-Fit"[™] Replacement Chassis, existing wall sleeves, existing front panels, gasketing and insulation must be checked and/or replaced.

Comitale National, Inc. is not responsible for the existing design, execution and performance of the installation method or any of the accessory items used during installation such as: seals, caulking, weather proofing, supporting structures, attachment means, wall sleeves, front panels, louvers and frames supplied by others or existing.

TABLE OF CONTENTS

GENERAL DESCRIPTION.....	3	CONDENSATE DISPOSAL	
MODEL DESIGNATIONS	3	COOLING CYCLE.....	9
MAJOR COMPONENTS	4	Prop. Fan Units Only	9
Compressor	4	Plastic Housings Only	9
Condenser		Metal Housings Only	9
Evaporator	4	CNI COOLING CHASSIS OPERATION ..	10
Thermostatic Expansion Valve	4	<i>Cooling Chassis by CNI,</i>	
Fresh Air Damper	5	<i>Control Box by Others</i>	<i>10</i>
Reversing valve (Heat pump only)	5	Cooling Operation	10
Bypass valve	5	Vent Operation	10
Motors	5	<i>Cooling Chassis and Control Box by</i>	
INSPECTION PROCEDURES	6	<i>CNI (Automatic Changeover).....</i>	<i>10</i>
Visual	6	Idle Operation.....	10
Operational	6	High/Low Operation	10
COMPONENT CHECK-OUT.....	6	Vent Operation	10
Compressor	6	<i>Cooling Chassis and Control Box by</i>	
Fan/motor.....	6	<i>CNI (Manual Changeover).....</i>	<i>10</i>
Outside Coil.....	7	Idle Operation.....	10
Inside Coil.....	7	Cooling Operation	10
Fresh Air Damper	7	Heating Operation	10
Expansion, Bypass, Reversing		Vent Operation	10
Valve Installation.....	7	CNI PRODUCT CODE SHEET.....	11
TOOLS AND INSTRUMENTS	7	DESIGNATION CHART	12
General	7	MAINTENANCE INSTRUCTIONS.....	13
Instruments/Tools	7	CNI Normal Maintenance.....	13
TROUBLESHOOTING CHART.....	8	Filter.....	13
CNI AIR CONDITIONING OPERATION.....	9	General Cleaning Operation.....	13
Idle Operation.....	9	Cooling Chassis	13
Cooling Operation	9	Unusual Maintenance and Service ..	13
Heating Operation	9	Preventative Maintenance.....	14
Vent Operation	9		

GENERAL DESCRIPTION

CNI Cooling/Heat Pump chassis assembly is a hermetically sealed, closed circuit refrigeration system that may be installed or removed from the wall sleeve simply by sliding in or out of the cabinet and making or breaking plug-in connections.

Within the available models of units, there are various chassis assemblies that range in cooling capacity from 7,000 BTUH to 18,000 BTUH. Assemblies are available for 115V/208V/230V, or 277V single-phase, 60 Hertz operation.

The chassis assembly is a heavy duty, slide-in assembly with base pan, condensate disposal

system, hermetically sealed refrigerant circuit and fresh air damper with filter.

In the cooling mode the condensate disposal system provides fast and 100% effective removal of condensate under all cooling operating conditions. Condensate from the cooling coil is drained from the drain pan into a tube in the condenser air stream where it is atomized and evaporated as it passes across the hot condenser coil

Chassis is fully insulated and is furnished with a quick disconnect plug to connect to power.

MODEL DESIGNATIONS

In some models, the chassis identification label is attached to the front of the chassis. In other models, an identification label is attached to the control box.

The identification label identifies the unit model number, voltage phase, full load amperes, type of refrigerant, and other pertinent data.

Refer to Page 11 and 12 for model codes and applications.

CNI

COOLING CHASSIS

Model no. CCC0C094-D10AS
208/230 volts 1 phase 60Hz
Min operating volts 197
CHASSIS AMPS:
FAN: 1.4/1.4 FLA
COOLING: 6.0/5.6 FLA 23.8 LRA
HEATING: FLA XXX LRA
REFRIGERANT-22 33.75 ozs
TEST PRESSURE 150 lo side 300 hi side
USE TIME DELAY FUSE MAX AMPS
SERIAL NO. 0210-0001
W.O. NO. 13060

CNI

COOLING CHASSIS

Model no. CMR0C094-000AS
208/230 volts 1 phase 60Hz
Min operating volts 197
CHASSIS AMPS:
FAN: 1.5/1.7 FLA
COOLING: 6.5/6.1 FLA 23.8 LRA
REFRIGERANT-22 33.75 ozs
TEST PRESSURE 150 lo side 300 hi side
SERIAL NO. 0210-0001
W.O. NO. 13060

CNI

HEATPUMP CHASSIS

Model no. CCC0H094-E10AS
208/230 volts 1 phase 60Hz
Min operating volts 197
CHASSIS AMPS:
FAN: 1.4/1.4 FLA
COOLING: 6.0/5.6 FLA 23.8 LRA
HEATING: 5.4/5.0 FLA 23.8 LRA aux heat FLA
REFRIGERANT-22 33.75 ozs
TEST PRESSURE 300 lo side 300 hi side
USE TIME DELAY FUSE MAX AMPS
SERIAL NO. 0210-0001
W.O. NO. 13060

CNI

HEATPUMP CHASSIS

Model no. CMR0H094-E10AS
208/230 volts 1 phase 60Hz
Min operating volts 197
CHASSIS AMPS:
FAN: 1.5/1.7 FLA
COOLING: 6.5/6.1 FLA 23.8 LRA
HEATING: 5.9/5.5 FLA 23.8 LRA
REFRIGERANT-22 23.375 ozs
TEST PRESSURE 300 lo side 300 hi side
USE TIME DELAY FUSE MAX AMPS
SERIAL NO. 0210-0001
W.O. NO. 13060

MAJOR COMPONENTS

Compressor

Chassis refrigerant compressor is a direct-connected motor compressor assembly enclosed within a steel housing and designed to pump low pressure refrigerant gas to a higher pressure.

This compressor is of the low pressure shell or housing type. This means that the compressor housing interior is subjected to suction pressure created by the stroke of the piston. This point is emphasized in order to stress the hazard of introducing high pressure gas into the compressor shell at pressures above 150 PSIG.

The motor within the compressor housing is designed to operate within a refrigerant gas atmosphere. It is of the Permanent Split Capacitor type (PSC). A run capacitor is in series with the start winding. Both run capacitor and start winding remain in the circuit during start and after the motor is up to speed. No start capacitor or relay is necessary.

Condenser

Condensers for all models are constructed of copper tubes expanded into aluminum fins. End plates are of 0.050 aluminum. Coils are either 2 or 4 rows deep and vary in length according to capacity requirements.

Evaporator

Evaporators for all models are constructed of copper tubes expanded into aluminum fins. End plates are of 0.050 aluminum. Coils are either 2, 3, or 4 rows deep and vary in length according to capacity requirements.

Thermostatic Expansion Valve

A thermostatic expansion valve regulates pressure in the refrigeration system, responding to pressure and temperature on the compressor suction line. It meters refrigerant to maintain evaporator conditions during compressor operation. The valve is factory set and is nonadjustable at the field level.

An additional feature of the thermostatic expansion valves used is its built-in provision for system pressure equalization during the off cycle. This is in the form of a small slot in the valve orifice (seat) to prevent complete valve

close off at the end of the compressor on-cycle. Due to this bleed spot, the valve does not close completely when the unit stops operating, but permits refrigerant to continue to flow at a small rate until the refrigeration system has equalized.

This feature permits the refrigeration compressor to start under no-load conditions and permits the use of PSC compressors.

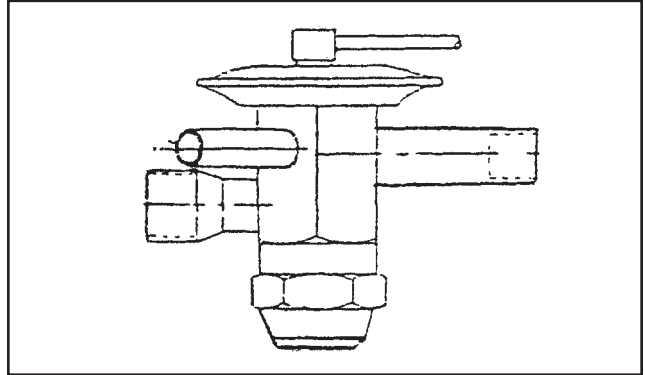

Thermostatic Expansion Valve

Fresh Air Damper

The chassis is equipped with a fresh air damper assembly that is solenoid operated.

When energized a solenoid opens the damper door and keeps the door in this position until de-energized. Upon de-energization, a spring closes and holds the damper door shut.

The fresh air inlet has a permanent, cleanable type filter.

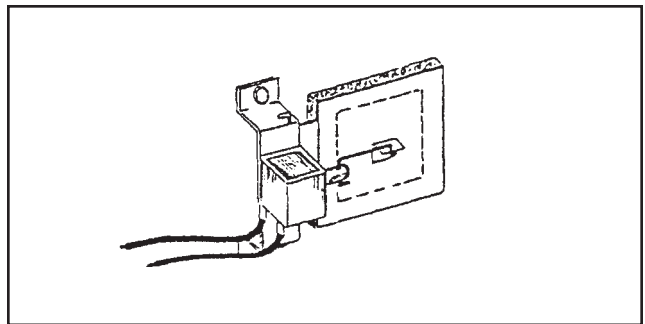

Typical Damper

MAJOR COMPONENTS Continued

Reversing Valve (Heat pump only)

Heating Cycle

With the 4 way solenoid reversing valve de-energized the system is on the heating cycle with the discharge and suction gases flowing thru the reversing valve ports making the indoor coil the condenser and the outdoor coil the evaporator.

Cooling Cycle

When the 4 way solenoid reversing valve is energized the system changes over to the cooling cycle with the discharge and suction gases flowing thru the reversing valve ports making the outdoor coil the condenser and the indoor coil the evaporator.

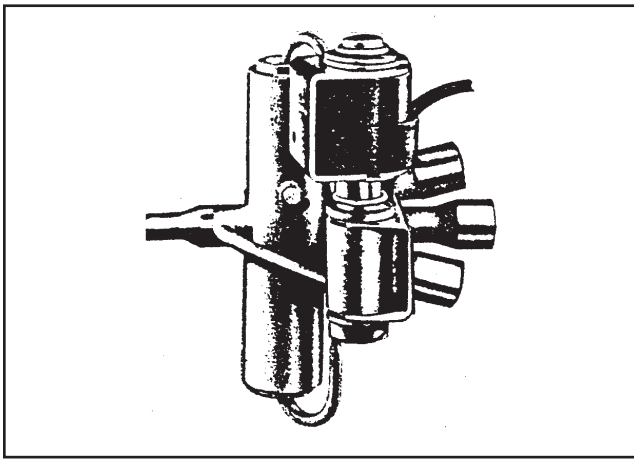

Reversing valve (Heat pump only)

Motors

Rugged PSC motors of the single and/or double shaft design are used in all refrigeration chassis.

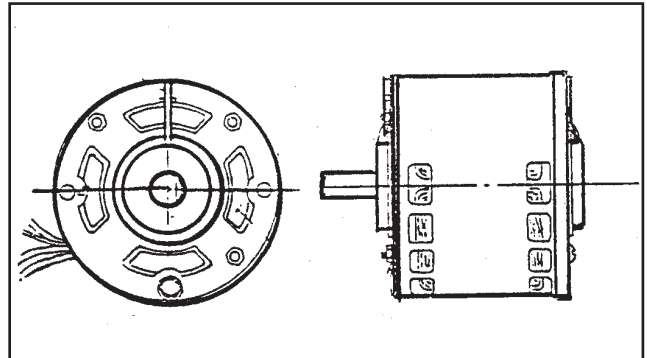

Single Shaft (Typical)

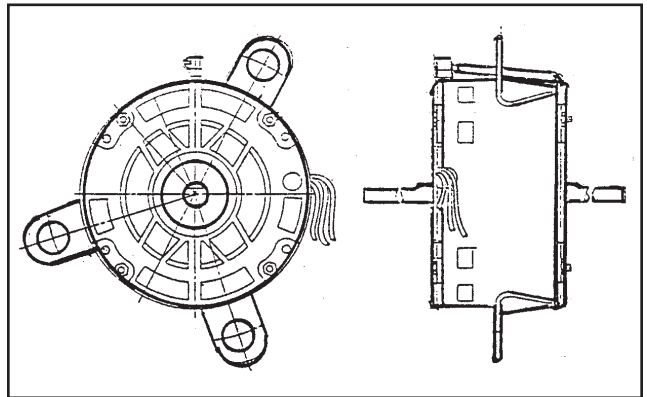

Double Shaft (Typical)

Bypass Valve

This valve will bypass hot discharge gas into the inside coil if the inside coil pressure falls below a pre-set pressure. This valve operates only in the air conditioning mode to prevent inside coil freeze up during light load conditions. This valve is non-adjustable at the field level.

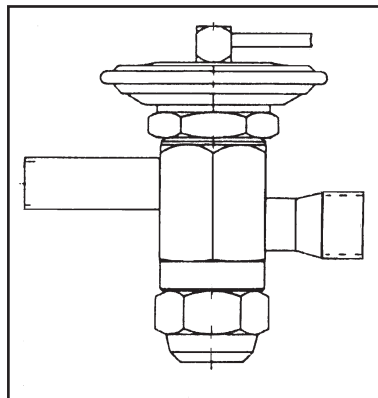

Bypass Valve

INSPECTION PROCEDURES

Visual

- a. Check all wires for signs of wear chafing or breaks.
- b. Check electrical connections to be sure they are secure.
- c. Fan motor and compressor capacitors must be mounted securely, have tight connections and not be blown out as far as a visual inspection can determine.
- d. Remove compressor terminal box cover and check connections to all terminals to make sure they are all intact and secure.

Operational

- a. Check supply voltage against unit nameplate.
- b. Install and electrically connect the chassis to the proper power.
- c. Operate chassis to determine the exact nature of the defect.
 1. If unit apparently operates satisfactorily - refer to component check out section and perform cleaning and lubrication procedures. Return unit to operation.
 2. If unit fails to operate, or operates improperly, it will be necessary to refer to the "Troubleshooting" section to check out components individually.

COMPONENT CHECK-OUT

Compressor

Run Capacitors

1. Disconnect the run capacitor from the system wiring.
2. Using a capacitor checker, connect the capacitor to the checker and check capacitor per instructions supplied with instrument.
3. Connect an ohmmeter between the capacitor case and both capacitor terminals (one at a time). Continuity indicates a grounded capacitor. Replace capacitor.

Motor Windings

1. Disconnect all leads to the compressor motor terminals.
2. Identify Start (S), Common (C), and Run (R) terminals of compressor.
3. Using an ohmmeter, check continuity across the following terminals combinations:
 - a. "C" to "S" - If no continuity, Start winding is open. If zero ohms, Start winding is shorted.
 - b. "C" to "R" - If no continuity, Run winding is open. If zero ohms, Run winding is shorted.
 - c. "C" to shell of compressor - If continuity, motor is grounded. If zero ohms, motor is shorted.

Run Test (Compressor in cooling chassis)

1. Apply power to start the compressor.
2. Observe amperage draw. If excessive or same as locked rotor rating as shown on compressor serial plate, compressor must be replaced.
3. Determine if compressor sound level is normal or excessive. If compressor sound level is abnormal, compressor must be replaced.
4. If compressor will not run, it is stuck and must be replaced.

Mounting

1. Inspect the compressor mounts to be sure they are free to move and rubber parts have not deteriorated.
2. Inspect studs for breaks or damage.

Fan/Motor

- a. Apply power to fan motor through its run capacitor. If motor fails to run, check:
 1. Power wiring for open circuit.
 2. Continuity of fan motor windings with ohmmeter.
 3. Motor wire for loose or bent connectors.
 4. Running capacitor with capacitor checker.

COMPONENT CHECK-OUT Continued

- b. Check amperage draw of fan motor against value listed on nameplate. If amperage is excessive, replace motor.
- c. Check orientation of fan motor. Air openings of motor must be facing down to prevent water from remaining in motor. Oilers must be facing up to prevent oil from running out.
- d. Check tightness of fan motor capacitor strap.
- e. Observe blower wheel to see that it is securely fastened to motor shaft and rotates freely within the scroll without rubbing or binding.
- f. Oil motor with a few drops of oil in each oiler.
- d. Remove drain tube and thoroughly flush drain tube. Dry drain tube and inspect for breaks or deterioration. Replace, if necessary.
- e. Clean and flush drain pan located under inside coil.

Fresh air damper

- a. Disconnect damper assembly linkage and the vent solenoid.
- b. Clean and lubricate damper linkage, using a light grease.
- c. Manually open damper door one inch. If when released the door does not close, door spring must be replaced.
- d. Check damper to make sure that the weather seal is secure.
- e. Reconnect damper assembly linkage and energize and de-energize the assembly with the Vent Switch.
- f. If damper door does not open, solenoid replacement is required.
- g. Inspect and clean or replace fresh air filter.

Outside Coil

- a. Wash outside coil with a mild soap and water solution, using a soft brush. Flush clean.
- b. Straighten fins with fin comb
- c. Inspect coils for damage, repair damaged areas or replace coil.
- d. Clean and flush drain pan located under outside coil.

Inside Coil

- a. Wash inside coil with a mild soap and water solution, using a soft brush. Flush clean.
- b. Straighten fins with fin comb.
- c. Inspect coils for damage, repair damaged areas or replace coil.

Expansion, Bypass, Reversing Valve Installation

- a. Recover system refrigerant.
- b. Un-braze valve from system tubing. Purge system with dry nitrogen during the un-brazing operation.
- c. Wrap the body of the new valve with a wet rag during the operation.

TOOLS AND INSTRUMENTS

General

In addition to general mechanics and refrigeration tools, there are some required instruments which are necessary to perform the test and repair procedures outlined in this manual.

- 1. Shop voltage requirements:
 - 115V, single phase, 60 Hertz
 - 208V, single phase, 60 Hertz
 - 230V, single phase, 60 Hertz
 - 277V, single phase, 60 Hertz

Instruments/Tools

- 1. Temperature recorder
- 2. Ohmmeter
- 3. Volt meter
- 4. Capacitor tester
- 5. Fin comb

TROUBLESHOOTING CHART

OPERATING FAULT	POSSIBLE CAUSE	CORRECTION
Compressor will not start - no hum	<ol style="list-style-type: none"> 1. Broken or loose wiring 2. Improper wiring 3. Overload protector tripped. 	<ol style="list-style-type: none"> 1. Check all wiring and connections 2. Check against wiring diagram 3. If external type
Compressor will not start - hums but trips on overload protector	<ol style="list-style-type: none"> 1. Improper wiring 2. Running Capacitor defective 3. Compressor motor has a winding open or shorted. 4. Internal mechanical trouble in compressor 	<ol style="list-style-type: none"> 1. Check against wiring diagram 2. Determine reason and replace 3. Replace compressor 4. Replace compressor
Compressor starts and runs, but short cycles on overload protector	<ol style="list-style-type: none"> 1. Additional current passing thru overload protector 2. Overload protector defective 3. Excessive discharge pressure 4. Suction pressure too high 5. Compressor too hot -return suction gas hot 6. Compressor motor has a winding shorted 	<ol style="list-style-type: none"> 1. Check against wiring diagram 2. Check current, replace protector (If external type) 3. Check for restrictions in condenser air flow or refrigeration circuit 4. Check for defective valves 5. Check refrigerant charge (fix leak) refrigerant, if necessary. Check reversing valve operation. 6. Replace compressor
Unit operates with little or no capacity	<ol style="list-style-type: none"> 1. Shortage of refrigerant 2. Restriction in refrigeration system 3. Dirty condenser 4. Defective TXV, by-pass, or reversing valves. 5. Inadequate air flow over evaporator 	<ol style="list-style-type: none"> 1. Fix leak, recharge 2. Determine location and remove 3. Clean condenser 4. Replace TXV, bypass, or reversing valves. 5. Clean evaporator coil, check fan, clean filter.
Condenser fan and vent motor runs, but compressor will not start	<ol style="list-style-type: none"> 1. Broken or loose wiring 2. Improper wiring 3. Defective running capacitor on compressor 4. Defective compressor overload protector 5. Defective compressor motor 	<ol style="list-style-type: none"> 1. Check all wiring 2. Check against wiring diagram 3. Replace capacitor 4. Replace overload Protector. (If external type) 5. Replace compressor
Electric shock from unit	<ol style="list-style-type: none"> 1. Improper grounding of electrical circuit 	<ol style="list-style-type: none"> 1. Check wiring diagram and provide proper ground
Water drips from unit	<ol style="list-style-type: none"> 1. Condensate drain plugged 2. Chassis damaged 	<ol style="list-style-type: none"> 1. Clean drain 2. Repair or replace damaged parts 3. Check installation in wall sleeve.
Unit vibrates or rattles	<ol style="list-style-type: none"> 1. Copper tube vibrating 2. Loose components 	<ol style="list-style-type: none"> 1. Adjust by bending or apply tape 2. Tighten and adjust as necessary

CNI AIR CONDITIONING OPERATION

Idle Operation

Depressing, the idle button terminates all functions except for compressor off-cycle heat.

Cooling Operation

Depress cool button. This energizes the reversing valve.

Select Hi-Lo fan speed.

Set room thermostat to satisfy desired room temperature

Air conditioner will bring room to desired temperature and continue to cycle compressor upon room thermostat demand.

Heating Operation

Depress heat button.

Select Hi-Lo fan speed.

Set room thermostat to satisfy desired room temperature.

Compressor in heating mode will bring room to desired temperature and continue to cycle compressor upon room thermostat demand.

If the compressor heating, mode does not satisfy heating load, the second stage of auxiliary heat will be automatically engaged when the room temperature falls approximately 3 degrees below room thermostat setting.

When outside air temperature falls below approximately 35 degrees F, the compressor will be automatically locked out. The locking out of the compressor will automatically switch room thermostat control to first stage auxiliary heat. This stage of auxiliary heat will cycle on and off based on room thermostat demand.

When outside air temperature rises back to approximately 45 degrees F the compressor heat pump cycle resumes operation.

Vent Operation

With the vent switch in the on position, the vent damper opens and outdoor air is directed thru the unit into the room after selecting Hi-Lo fan speed.

The vent damper closes automatically when either the vent switch is turned off or the idle button is depressed.

CONDENSATE DISPOSAL COOLING CYCLE

Metal Housings

The condensate from the inside coil is thrown up onto the hot outside coil and is re-evaporated by means of slit in the fan housing that draws water from the base pan and discharges it into the outside fan air stream.

CNI COOLING CHASSIS OPERATION

COOLING CHASSIS BY CNI, CONTROL BOX BY OTHERS

Cooling Operation

Upon call for cooling from the existing control box the compressor and outside fan motor will be energized and cool air will be supplied to the conditioned space for as long as the control box continues to call for cooling.

Vent Operation

Upon call for ventilation from the existing control box, the vent damper will open to introduce outside air to the conditioned space. Separate outside motor units. Depending on control box wiring, the outside fan may run.

COOLING CHASSIS AND CONTROL BOX BY CNI

(AUTOMATIC CHANGEOVER)

Idle Operation

Depressing idle button terminates all functions of the unit.

High/Low Operation

Depressing the high or low button selects the indoor fan speed and energizes the system for heating or cooling, depending on room thermostat set point versus room temperature.

Vent Operation

Combination Inside/Outside Motor

With the vent switch in the on position, the vent will open to introduce outside air to the conditioned space as long as the Hi or Lo buttons are depressed.

COOLING CHASSIS AND CONTROL BOX BY CNI

(MANUAL CHANGEOVER)

Idle Operation

Depressing the idle button terminates all functions of the unit.

Cooling Operation

Depress cool button to activate the cooling mode and select either hi or lo fan speed. The compressor will operate upon demand of the room thermostat.

Heating Operation

Depress heat button to activate the heating mode and select either hi or lo fan speed. The heating section (electric or hydronic) will operate upon demand of the room thermostat.

Vent Operation

Combination Inside/Outside Motor

With the vent switch in the on position the vent will open to introduce outside air to the conditioned space as long as the heat or cool buttons are depressed.

Vent Operation

Separate Motor

Operation is the same as above except that the outside motor will also be energized with the vent switch.



Comitale National, Inc.

Product Code Sheet

(Z in any box = Special)

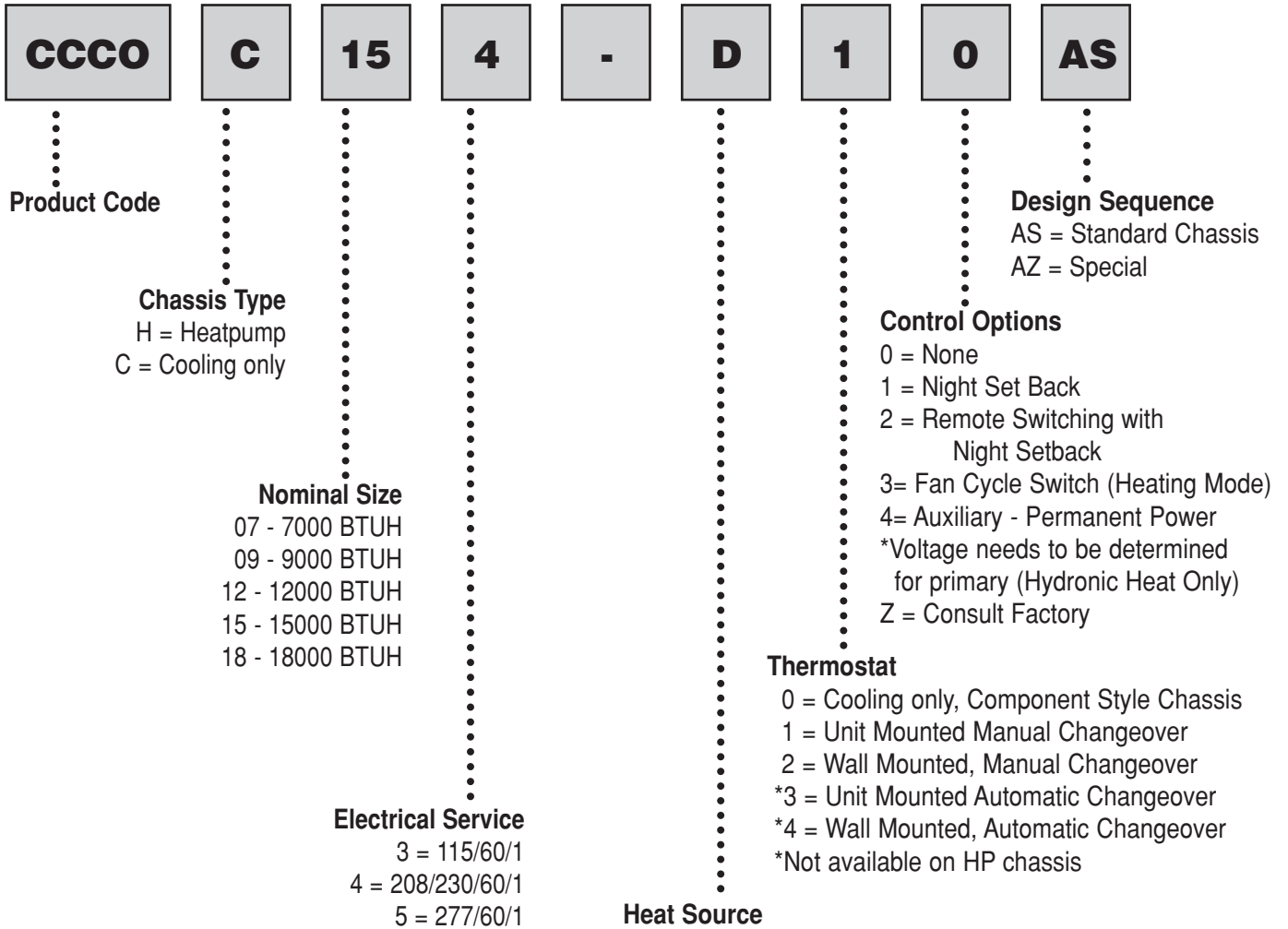

The sample unit coding above indicates a **CNI** Cooling Chassis for replacement of a Nesbitt® Challenger; 15000 BTUH, 208-230/60/1, Hydronic Heat, Unit Mounted, Manual Changeover, No Control Options, Standard.

Z = Specials
Outlined in Spec.

DESIGNATION CHART

CNI CODE	CHASSIS TYPE	REFRIG. CHASSIS	HEATING SECTION		INDOOR FAN REMOVABLE MOTORBOARD	SYSTEM CHASSIS CONTAINED FAN	OUTDOOR FAN TYPE	CONDENSATE DISPOSAL SYSTEM	CONTROL BOX
			ELECTRIC	HYDRONIC					
CCC0	CC HP	Included	Optional	Optional	N/A	Included	Blower	Slit	Included
CAF160	CC HP	Included	Optional	Optional	N/A	Included	Blower	Slit	Included
CTPI0	CC HP	Included	Optional	Optional	Included	Included	Blower	Slit	Included
CFO0	CC HP	Included	Optional	Optional	N/A	Included	Blower	Slit	Included
CA450	CC HP	Included	Optional	Optional	N/A	Included	Blower	Slit	Included
CRS0	CC HP	Included	Optional	Optional	Included	Included	Blower	Slit	Included
CEAF0	CC HP	Included	Optional	Optional	Included	Included	Blower	Slit	Included
CSEA0	CC HP	Included	Optional	Optional	Included	Included	Blower	Slit	Included
CSHA0	CC HP	Included	Optional	Optional	Included	Included	Blower	Slit	Included
CEAL0	CC HP	Included	Optional	Optional	Included	Included	Blower	Slit	Included
CEARO	CC HP	Included	Optional	Optional	Included	Included	Blower	Slit	Included
CWRB0	CC HP	Included	Optional	Optional	Optional	Included	Blower	Slit	Included
CMR0	CC HP	Included	Optional	Optional	Optional	N/A	Blower	Slit	Optional
CRP0	CC HP	Included	Optional	Optional	Optional	N/A	Blower	Slit	Optional
CRK0	CC HP	Included	Optional	Optional	Optional	N/A	Blower	Slit	Optional
CNIII0	CC HP	Included	Optional	Optional	Optional	N/A	Blower	Slit	Optional
CAF250	CC HP	Included	Optional	Optional	Optional	N/A	Blower	Slit	Optional
CA410	CC HP	Included	Optional	Optional	Optional	N/A	Blower	Slit	Optional
CRJ0	CC HP	Included	Optional	Optional	Optional	N/A	Blower	Slit	Optional

NOTE: CC = COOLING APPLICATION HP = HEAT PUMP APPLICATION
 INCLUDED = CONTAINED IN SLIDE-IN CHASSIS OPTIONAL = SEPARATE SECTION

MAINTENANCE INSTRUCTIONS

CNI Normal Maintenance

This is a simple procedure and should be performed on a scheduled basis by normal maintenance personnel.

Filter

Clean or replace air filter regularly (Every six months or as required)

Filter change or clean with soap and water.

****Important Do not run unit without filter.***

General Cleaning Operation

(Once a year or as required)

Should be performed on a regular basis of once a year. Frequency depends on local atmospheric conditions and application. Complete cleaning should not exceed three years.

1. Remove chassis from wall sleeve.
2. Short out all capacitors, then disconnect capacitor wires.
3. Chassis should be taken to work area to perform clean-up operations. (See instructions following step No. 10)
4. Vacuum and thoroughly clean piping compartments, inside of cabinet and wall sleeve.
5. Inspect wiring for tight connections in electrical compartments.
6. Inspect pipes for leaks.
7. Clean outdoor grille with water and mild detergent, using soft brush.
8. Clean bottom of wall sleeve.
9. Replace or repair insulation and rubber seals on cooling chassis and room cabinet where required (with same type).

Cooling Chassis

10. Remove condenser unit top cover from cooling chassis.
11. Every three years or 12,000 running hours lubricate the bearing of the condenser and evaporator motor with SAE-20 or commercial grade electric motor oil. Use approximately 1 teaspoon oil. ***DO NOT OVERFILL!***
12. Wash evaporator and condenser coils with evap power "C" coil cleaner.
13. Remove drain tube and flush both sides.
14. Clean and flush drain pan at both ends.
15. Dry all parts of equipment thoroughly.
16. Replace metal panels and tighten screws.
17. When reconnecting capacitor follow diagram on chassis.
18. If damper is furnished, clean and lightly grease linkage.
19. Test-run cooling chassis before returning unit.

****Important: Do not stop or start unit on cooling more than once within 3 minute cycle.***

Unusual Maintenance and Service

Unusual maintenance is required when equipment does not function properly. If electrical service is performed, turn power off at unit and source, which is located at buildings central control panel. This type of maintenance which includes refrigeration service, should only be performed by factory authorized service agencies or trained refrigeration mechanics.

First, check the following before calling:

1. Check switches and fuses or circuit breaker to make sure power is on.
2. Make sure all plugs are properly seated.
3. See nameplate for required voltage to unit and check voltage at source.
4. Be sure filter is clean.
5. Check proper control sequence and operation procedure.

Preventative Maintenance

A scheduled and properly executed maintenance program will minimize and possibly prevent special maintenance. It is not unusual for the **C.N.I.** "Tru-Fit" to have component replacement rate of less than one percent to facilitate maintenance and insure that each unit will be available for operation, maintain a small stock of replacement components.

For example: Based on 100 units, stock the following:

- One complete cooling chassis per unit size.
- One evaporator and condenser motor and fan assembly per unit size.
- 100 pcs. Replacement filters - depending on usage.
- 10 pcs. Cleanable filters - depending on usage.



Comitale National, Inc.

1683 B Winchester Road • Bensalem, PA 19020

215-244-9650 • FAX 215-244-9679

email:cnitrufit@aol.com

Original Equipment Manufacturer of Custom Package Terminal Air Conditioners and National H.V.A.C. Parts Distributor.