

The Eliminator™

*Optimum
Dehumidification*

*Low Cost
Operation*



*The ideal Industrial
Dehumidifier to stop rust,
mildew, mold, rot, decay,
warp, stretch, drip, spotting
and other types of damage
induced by excessive
moisture conditions.*



Comitale National Inc.
776 Haunted Lane • Bensalem, PA 19020
215-244-9650 • Fax 215-244-9679 • E-Mail cnitrufit@aol.com
www.comitalenational.com

The rugged new CNI Eliminator™ Industrial Dehumidifier dries air automatically, without fuss or hard to deal with chemicals; and it does it at an astonishing low cost.

No recognized method of air drying, within its recommended operating range is as economical in first cost or operating cost as the Eliminator. In comparison to absorption and suction adsorption equipment, the CNI Industrial Dehumidifier usually costs less than half as much to own and operate in equivalent moisture removal.

Selecting the CNI Eliminator to Solve Your Humidity Problems!

Actual moisture removing capacity is determined by operating temperature and relative humidity. It may range from as little as three gallons of water per day to 36 gallons of water per day.

The CNI Industrial Dehumidifier is designed to operate most effectively at ambient dry bulb temperatures between 55 F (13 C) and 105 F (41 C), and at relative humidities from 40% to 100%. If equipment is required for operating conditions other than those shown in this catalog, consult the factory.

Step 1: Determine amount of moisture that must be removed from air infiltration to your space

- A. Identify the maximum moisture content of the outside air in your locality, from Table 1. Select the city closest to your area.
- B. Determine the maximum amount of moisture that must be removed from every 1,000 cu. ft. of air entering your facility at a given temperature, to satisfy your requirement for a selected humidity. From Table 2, enter usual indoor temperature on hot, muggy days and read pints of water at desired relative humidity. Deduct this from the figure selected in Step 1A.
- C. Establish the total volume of space where the humidity is to be controlled. Multiply interior building or space, width by length by height, to determine cubic feet.
- D. From Table 3 select the appropriate infiltration factor for your plant. Multiply this factor by the total volume (cu. ft. from Step 1C) to determine the cubic feet per hour infiltrating your space.
- E. Multiply the moisture removal requirement as established in Step 1B by the total air infiltrating your facility as established in Step 1D.

Step 2: Determine the effect of occupancy on humidity levels

People occupying the space give up moisture. The amount of moisture released is dependent on the degree of activity. Table 4 identifies the amounts of moisture given up for various types of activities. Referencing this table, compute the moisture that must be removed every hour to compensate for the number of people and the type of activity performed within your space.

Step 3: Determine from standing water

If your operation requires open tanks or sinks of standing water which can evaporate into the air, it will be necessary to identify the temperature of the standing pool and the exposed surface area. Referencing Table 5, identify pints of water that will be evaporated for every square foot of surface area at the usual water temperature.

Step 4: Identify other sources of moisture

For instance, if your space houses equipment that burns unvented natural or manufactured gas, the hydrogen in the gas will combine with oxygen in the air to form moisture. This is another source of humidity that must be controlled. Determine the amount of gas burned in cu. ft. per hour and multiply it by .65 for natural gas or .35 for manufactured gas to determine the pints of water per hour that must be removed. Additional sources of moisture might include wiping cloths or the products being manufactured, or packaged. In each case some effort must be made to establish the amount of water that will be given up in order to maintain humidity levels.

Step 5: Summary Data

1. Water from infiltrating air.....	_____	Pts/Hour
2. Water from occupancy	_____	Pts/Hour
3. Water from evaporation.....	_____	Pts/Hour
4. Water from other sources.....	_____	Pts/Hour
<hr/>		
Total to be removed each hour to maintain humidity levels.....	_____	Pts/Hour

Step 6: Machine Selection

Identify the moisture removal capacity of the Eliminator for a given room temperature and relative humidity from Table 6. More than one piece of equipment may be necessary.

MAXIMUM MOISTURE CONTENT OF OUTDOOR AIR BY LOCALITY

STATE and CITY	PINTS PER 1000	STATE and CITY	PINTS PER 1000	STATE and CITY	PINTS PER 1000	STATE and CITY	PINTS PER 1000
ALABAMA		INDIANA		NEBRASKA		SOUTH CAROLINA	
Birmingham	1.23	Indianapolis	1.20	Lincoln	1.09	Charleston	1.36
Mobile	1.40	IOWA		Omaha	1.20	TENNESSEE	
ARIZONA		Des Moines	1.23	NEW JERSEY		Memphis	1.32
Phoenix	1.16	KANSAS		Atlantic City	1.28	Nashville	1.28
Tucson	.99	Wichita	1.16	NEW YORK		TEXAS	
ARKANSAS		KENTUCKY		New York City	1.20	Dallas	1.23
Little Rock	1.36	Louisville	1.23	Rochester	1.13	Houston	1.32
CALIFORNIA		LOUISIANA		NORTH CAROLINA		San Antonio	1.32
Los Angeles	.96	New Orleans	1.40	Raleigh	1.28	VIRGINIA	
San Diego	.99	MARYLAND		Richmond	1.28	WASHINGTON	
San Francisco	.79	Baltimore	1.28	Cincinnati	1.23	Seattle	.75
CONNECTICUT		MASSACHUSETTS		Cleveland	1.13	WISCONSIN	
Hartford	1.20	Boston	1.16	Columbus	1.16	La Crosse	1.20
FLORIDA		MICHIGAN		OKLAHOMA		Milwaukee	1.16
Miami	1.32	Detroit	1.13	Tulsa	1.23	WASHINGTON D.C.	
GEORGIA		MINNESOTA		OREGON			
Atlanta	1.20	St. Paul	1.16	Portland	.84		
Savannah	1.36	MISSOURI		PENNSYLVANIA			
ILLINOIS		Kansas City	1.20	Philadelphia	1.23		
Chicago	1.16	St. Louis	1.23	Pittsburgh	1.05		
Moilne	1.23						

AMOUNTS OF MOISTURE CONTAINED IN AIR

AIR TEMP. DEG. F.	ACTUAL RELATIVE HUMIDITY OF AIR IN %						
	90	80	70	60	50	40	30
PINTS OF WATER CONTAINED IN 1,000 CU. FT. OF AIR							
100	2.56	2.28	2.00	1.71	1.43	1.14	.86
95	2.22	1.98	1.73	1.48	1.23	.99	.74
90	1.92	1.71	1.49	.128	1.07	.85	.64
85	1.65	1.47	1.29	1.10	.92	.74	.55
80	1.42	1.28	1.10	.95	.79	.63	.47
75	1.21	1.08	.95	.81	.68	.54	.41
70	1.03	.92	.80	.69	.57	.46	—
65	.88	.78	.68	.59	.49	—	—
60	.75	.68	.58	.50	.41	—	—

INFILTRATION FACTORS

BUILDING TYPE	INFILTRATION FACTORS	
	Minimum	Maximum
Normal Factory Building	½	1½
Normal Commercial Building	½	1½
Good Frame Construction	1	2
Poor Frame Construction	1½	3
Corrugated Iron Construction	1½	3

Use "Minimum" if building has few or no windows, etc.
Use an intermediate factor if the building has an average number of tight windows.
Use "Maximum" if building has many windows.

MOISTURE FROM PEOPLE

TYPE OF ACTIVITY	MOISTURE PER PERSON
Seated at rest	0.15 pints/hour
Office Work	0.25 pints/hour
Light Factory Work	0.5 pints/hour
Moderate Heavy Factory Work	0.7 pints/hour
Heavy Factory Work	1.0 pints/hour

This table assumes 70°-80°F. indoor Temperatures. For 90° increase values by 10%; for 100° increase values by 25%.

MOISTURE FROM OPEN WATER TANKS

WATER TEMPERATURE DEGREES F.	WATER EVAPORATED - PINTS PER HOUR PER SQ. FT. OF WATER SURFACE
70	0.02 Pints
80	0.05 Pints
100	0.13 Pints
120	0.27 Pints
140	0.50 Pints
160	0.83 Pints
180	1.37 Pints

This table assumes relative Still Room Air at 80°F. Temperature and 50%Relative Humidity.

CNI ELIMINATOR DEHUMIDIFIER SELECTION

ROOM AIR TEMP. °F	WATER REMOVAL IN PINTS PER HOUR AT DESIRED RELATIVE HUMIDITY %						
	100	90	80	70	60	50	40
105	*	12.1	11.8	10.5	9.0	7.2	5.6
100	12.3	11.9	11.3	9.8	9.3	6.9	5.2
95	12.0	11.5	10.9	9.5	8.6	6.5	4.8
90	11.6	11.0	10.4	9.1	7.6	6.0	4.2
85	11.4	10.5	9.6	8.4	6.9	5.4	3.5
80	10.7	9.8	8.7	7.6	6.3	4.8	2.9
75	9.9	8.9	7.9	6.7	5.5	4.1	2.5
70	9.1	8.2	7.0	5.6	4.2	2.7	1.3
65	8.2	7.3	6.2	4.5	3.0	1.8	0.8
60	7.2	6.2	4.9	3.4	2.0	1.2	*
55	6.3	5.2	3.8	2.1	1.2	*	*
50	5.2	4.0	2.8	1.3	*	*	*

NOTE: Reduce tabular ratings by 1/7th when operating on 50-cycle current. Net sensible heat gain to space is approx. 3500 BTUH.

* Equipment will not operate at these conditions.

Details & Dimensions

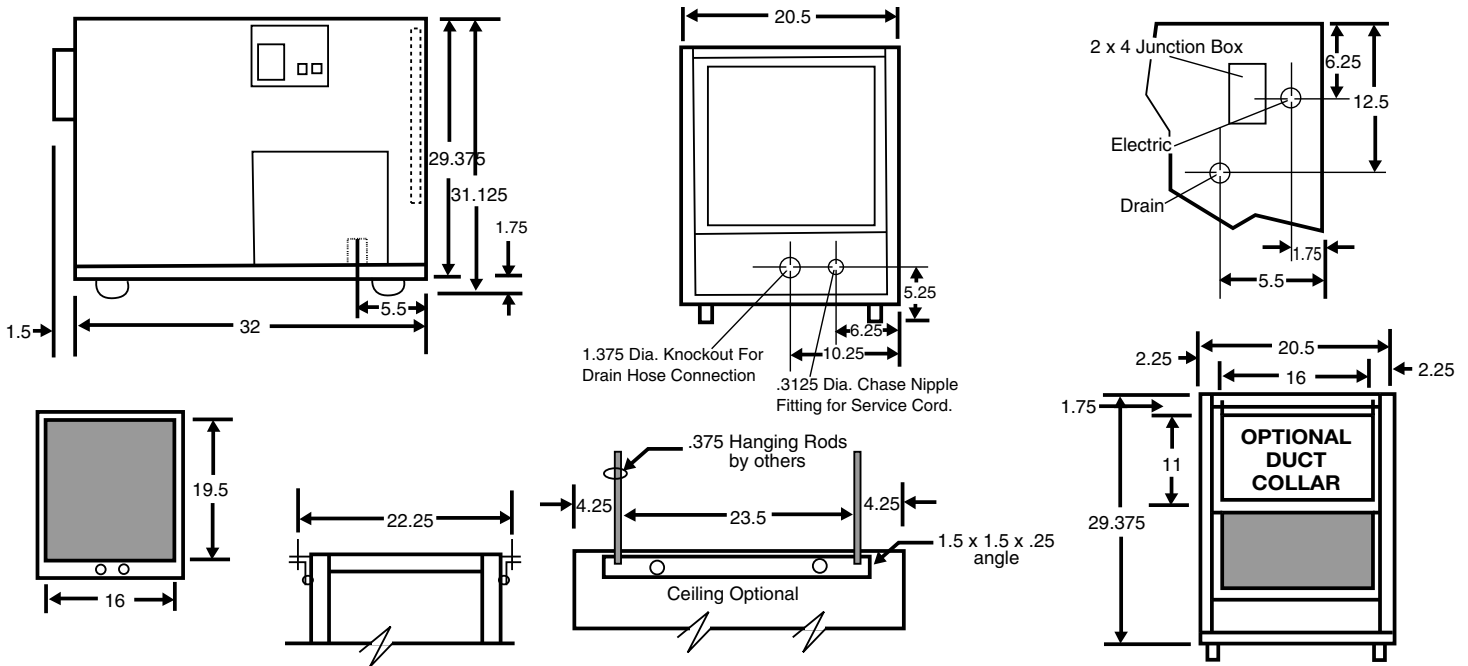

Capacity Data & Specifications

Capacity measured according to ANSI Standard B149.1

COMPRESSOR PERFORMANCE DATA						FAN PERFORMANCE DATA				
Capacity* 24 Hours	Compressor HP	Voltage	Phase	Full Load Amps	LRA	Blower HP	Voltage	Phase	Full Load Amps	RPM
140 pints	1¼	208/230	1	7.4	48.2	1/8	208/230	1	1.8	1050

PERFORMANCE DATA					SHIPPING DATA	
Circuit Breaker	Unit Width	Unit Depth	Unit Height	Connections Water Out	SHIPPING WEIGHT	
					Domestic	Export
20 AMP	20½"	32"	31¾"	3/4" MPT Hose Connection	250#	330#

* Capacity based on 80°F and 60% RH

Cabinet and structure are constructed of 18 gauge minimum galvanized steel. Cabinet panels are phosphatized and finished in powder coat of light beige. Top panel is easily removable for ready access to working parts.

Casters are furnished to facilitate moving the dehumidifier.

Operating Cycle Dehumidification is accomplished by means of a direct expansion cycle. Room air is drawn into the dehumidifier and cooled below the ambient dew point temperature. This results in condensing water vapor from the room air. The air is then passed through the refrigerant condenser coil and reheated.

Compressor is a heavy duty hermetically sealed, commercial type with built-in thermal overload protection.

Coils both the evaporator and condenser coils are multi-row design, made of copper tubing and aluminum fins.

Refrigerant is Type R-22.

Electrical Characteristics Standard units shall be designed for 208-230 volt, 60 cycle, single phase. As an option, the unit is available for 230 volt, 50 cycle, single phase.

Power Cord has three wires with a three-prong plug for grounding.

Blower Assembly has a double inlet centrifugal fan with a direct drive PSC motor. Motor has built-in thermal overload protection.

Power Control is conveniently located On-Off switch of the push button type.

Humidity Control is accomplished by an adjustable line voltage humidistat. The humidistat shall start and stop the compressor to maintain the desired humidity level in the conditioned space. The blower continues to circulate room air as long as the power control is on. Humidistat range is 20% to 80% relative humidity.

Automatic Temperature Compensation is accomplished by a thermostatic expansion valve. This valve assures maximum air drying capacity over a wide range of ambient temperatures.

Condensate Disposal Holes are provided in the floor of the cabinet for the passage of a hose or permanent drain piping. The drainpan is equipped with a male hose connection. A 5-gallon pail is supplied for use in areas where other drain means are not available.

Air Filter (Nominal 16 x 20 x 1) is provided to protect the coils and motor from dirt. The filter is easily replaceable without tools.

LIMITED WARRANTY — The CNI Eliminator is warranted to be free from defects, under normal installation, use and service for one year. For an additional cost, an extended two to five year warranty is available for the compressor only.

Built-In Jobs — Consult factory for certified submittal data. On built-in jobs, the casters are removed so the cabinet will rest flush on the floor and electric connections are made to the junction box, supplied as standard equipment.

In the interest of product improvement, specifications and dimensions are subject to change without prior notice.



Comitale National Inc.
 776 Haunted Lane • Bensalem, PA 19020
 215-244-9650 • Fax 215-244-9679 • E-mail
 cnitrufrif@aol.com
 www.comitalenational.com